

Tetra[®] Contour LS

LED Lighting System

Tools and Components

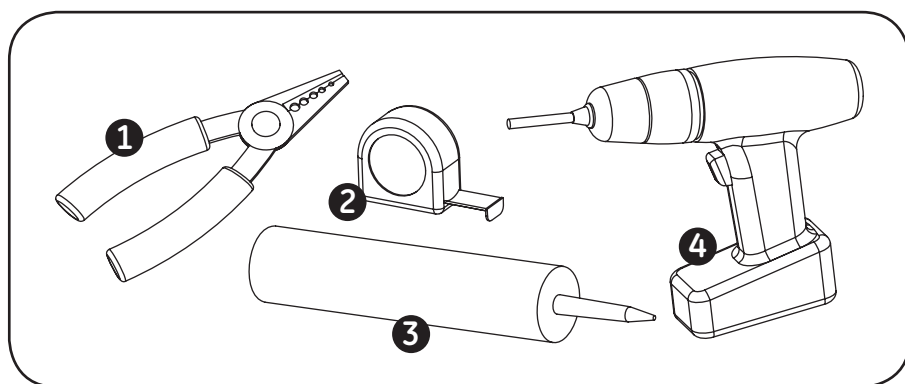

Tools required:

- 1 Wire stripper/cutter
- 2 Tape measure
- 3 Electrical grade silicone
- 4 Cordless drill

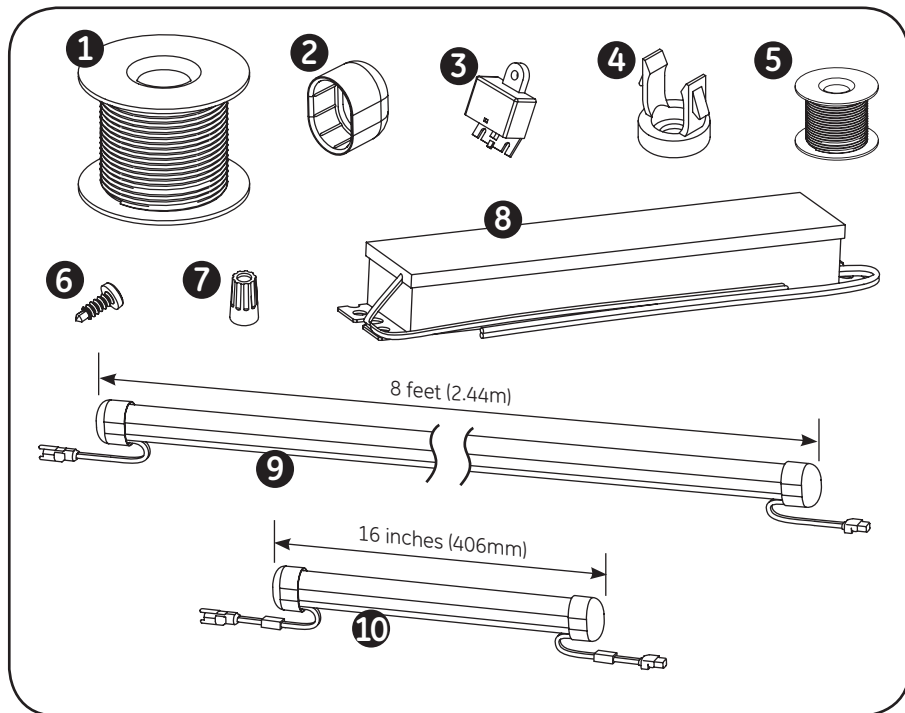

Components required:

- 1 UL approved 18 AWG (0.82mm²) supply wire
- 2 End Caps
- 3 Weather Boxes
- 4 Light Guide Mounting Clips
- 5 22 AWG (0.33mm²) tie-wire
- 6 #6, #8 or #10 (M2, M3 or M4) self drilling pan headed screws
- 7 UL approved twist-on wire connectors fitting both 18 and 20 AWG wire (0.82mm², 0.52mm²)
- 8 Power Supply (GEPS24-20, GEPS24-80 or GEPS24-100U)
- 9 Tetra[®] Contour LS
- 10 **Optional:** Tetra[®] Contour LS extension



Planning

For planning the layout, measure the perimeter of the building and divide by 8 ft. (2.44m) to determine the required quantity of Tetra Contour LS systems. See table below for guidelines about cutting resolution.

For seamless designs, accessories are available for straight runs and 90 degree corners.

NOTE: Do not use more than one suffix code for each respective application, as mixing suffix codes may result in appearance variation. Suffix code can be found on the packaging label.

Cutting Resolution Table

Tetra Contour LS

SKU	Color	Cutting Resolution
GERDXNLA2-RD	Red	8 inches (203mm)
GEGLXNLA2-GL	Green	8 inches (203mm)
GEBLXNLA2-BL	Blue	8 inches (203mm)
GEWHXNLA2-WH	White	8 inches (203mm)

Tetra Contour LS extension

SKU	Color	Cutting Resolution
GERDXNAA2-RD	Red	2.67 inches (68mm)
GEGLXNAA2-GL	Green	2.00 inches (51mm)
GEBLXNAA2-BL	Blue	2.00 inches (51mm)
GEWHXNAA2-WH	White	2.00 inches (51mm)

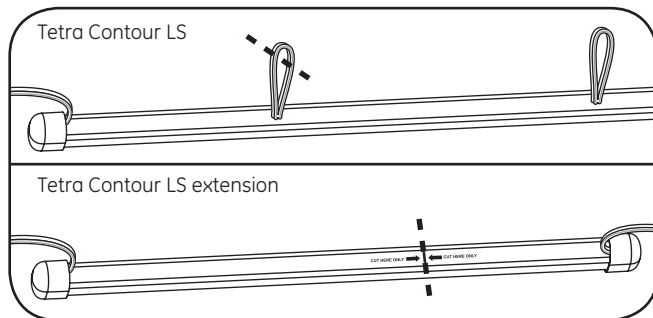

- 1 If it is necessary to cut the Tetra Contour LS for a better fit, refer to the Cutting Resolution table above.

NOTE: Tetra Contour LS can only be cut on wires.

NOTE: Tetra Contour LS extension sections can only be cut on "Cut Here" markings.

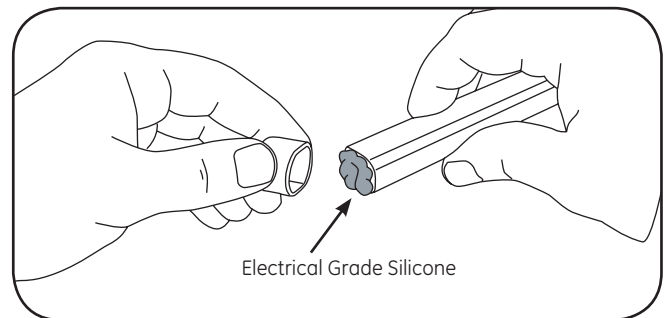

- 2 If Tetra Contour LS sections are cut, apply electrical grade silicone to exposed wires and attach end cap.

CAUTION

Risk of damage. Must use electrical grade silicone.

Attaching Contour Sections

NOTE: Tetra Contour LS is intended for straight runs.

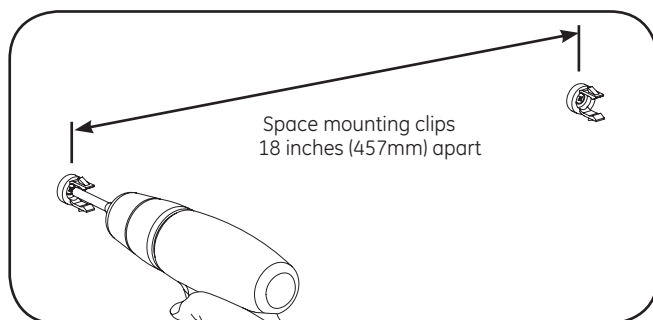

- 1 Install one mounting clip at each end and then a minimum of one mounting clip every 18 inches (457mm).

NOTE: Standard neon mounting hardware can also be used.

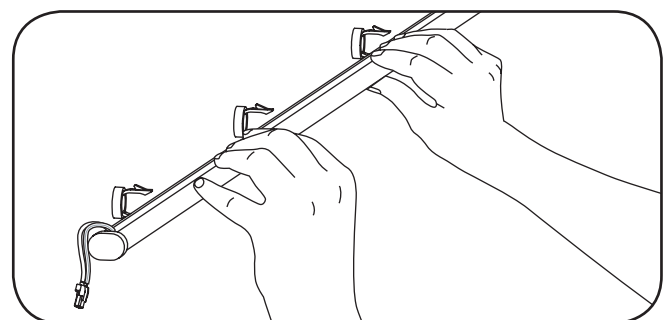

- 2 Starting from one end, attach the Tetra Contour LS to the mounting clips. Secure light guide by twisting tie-wire around the mounting clip and light guide.

NOTE: Wires can be concealed by tucking wires between mounting clips and Tetra Contour LS system.

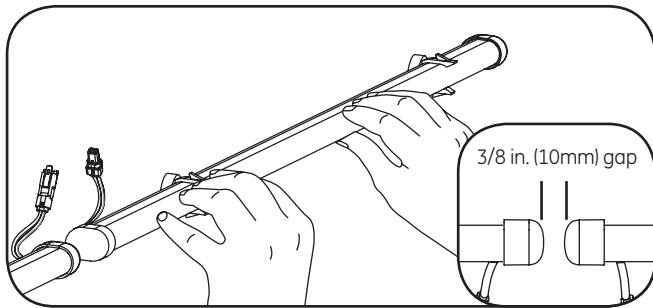

3 Continue attaching all the sections to the remaining mounting clips, leaving a 3/8 inch (10mm) gap between sections to allow for expansion or contraction.

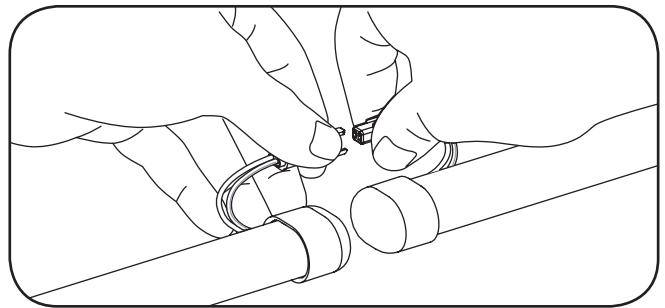

4 Plug together all adjacent Tetra Contour LS sections and tuck wires behind Tetra Contour LS sections or behind accessory pieces.

Electrical Connections

Must be used with the **GEPS24-20, GEPS24-80 or GEPS24-100U Power Supplies** (24 Volt). Refer to the **Power Supply Installation Instructions** for more information on the power supply.

⚠ WARNING

Risk of electrical shock. Turn power OFF before inspection, installation or removal.

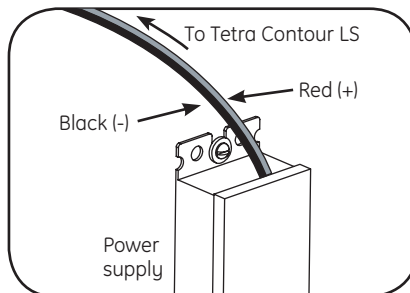

1 Run a wire from the power supply to a section of Tetra Contour LS.

NOTE: Power supply connection must be contained in an acceptable UL/NEMA enclosure.

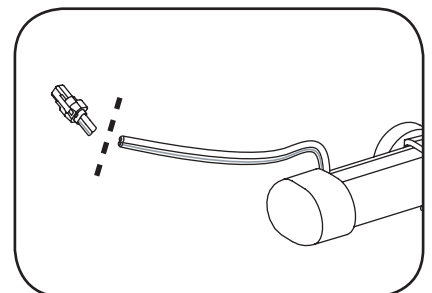

2 Cut off the quick connector on the Tetra Contour LS that you are connecting to the power supply.

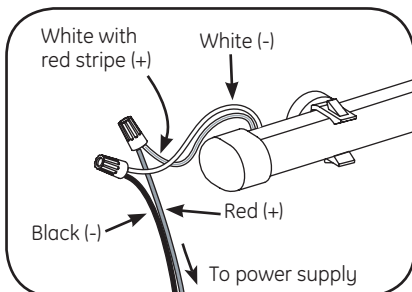

3 Using twist-on wire connectors, connect the white wire with red stripe (+) from the LED strip to the red wire (+) of the power supply. Connect the white wire (-) from the LED strip to the black wire (-) of the power supply.

NOTE: Grounding and bonding must be done in accordance with National Electrical Code (Article 600). See power supply instructions.

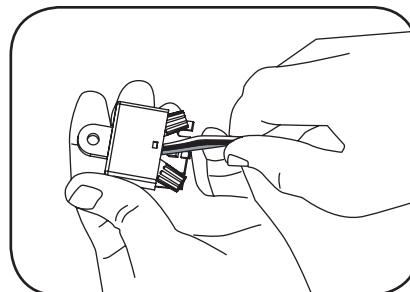

4 Insert wire connectors into weather box. Fill with electrical grade silicone and close box.

NOTE: Examples of electrical grade silicone include GE RTV 6700 Series Sealant, GE White Blanc RTV 162, Dow Corning 3145, Dow Corning RTV 748

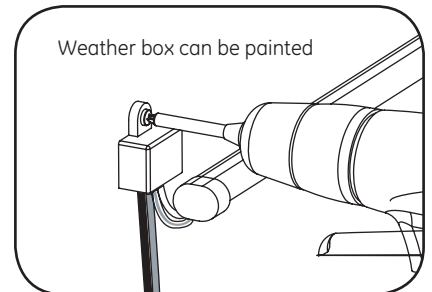

5 Secure the weather box using a #6 or #8 (M2 or M3) screw.
NOTE: When using twist-on connectors, weather box is required for all outdoor electrical connections.

Power Supply	Maximum Power Supply Loading	Remote Mounting Distance
GEPS24-20	6 ft. (1.83m)	1-120 ft. (0.30-36.6m) 18 AWG (0.82mm ²) supply wire
GEPS24-80	24 ft. (7.32m)	1-30 ft. (0.30-9.14m) 18 AWG (0.82mm ²) supply wire
GEPS24-100U	30 ft. (9.14m)	1-30 ft. (0.30-9.14m) 18 AWG (0.82mm ²) supply wire

Optional—Attaching Tetra Contour LS to Tetra Contour

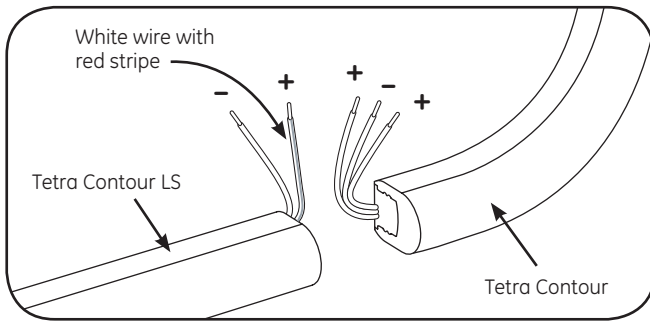

- 1** When connecting Tetra Contour LS to Tetra Contour, separate wires and identify conductors as positive (+) and negative (-). Strip ends back 0.5 in. (12mm).

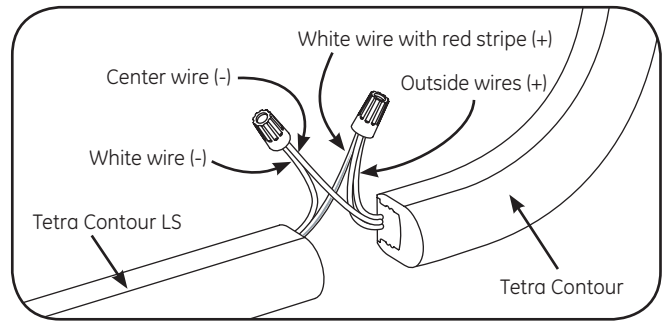

- 2** Splice the white wire with red stripe (+) of Tetra Contour LS to the two outside wires (+) of Tetra Contour and splice the white wire (-) of Tetra Contour LS to the center wire (-) of Tetra Contour.

NOTE: Weather box is required for all outdoor electrical connections.

Troubleshooting

Symptom	Solution
All sections are OFF	<ul style="list-style-type: none"> • Check AC input connection and/or check circuit breaker. • Check wire connection(s) at the Tetra Contour LS section and power supply for improper termination(s) or short circuits. Properly terminate or replace the wire connection(s). • Check that connections are the white wire with red stripe (+) of the LED strip to the red wire (+) of the power supply and the white wire (-) of the LED strip to the black wire (-) of the power supply.
Some LEDs appear dim	<ul style="list-style-type: none"> • Ensure the overall length of the Tetra Contour LS does not exceed the maximum load. • Ensure the length of supply wire from the power supply is equal to or below the recommended remote mounting distance. • Make sure that all LED light engines have the same suffix code (suffix code is located on the box label).
Some of the sections are not illuminated	<ul style="list-style-type: none"> • Check wire connection(s) at the Tetra Contour LS section and power supply for improper termination(s) or short circuits. Properly terminate or replace the wire connection(s). • Check that connections are the white wire with red stripe (+) of the LED strip to the red wire (+) of the power supply and the white wire (-) of the LED strip to the black wire (-) of the power supply.

⚠ WARNING!

RISK OF ELECTRIC SHOCK:

- Turn power OFF before inspection, installation or removal.
- Properly ground Tetra Power Supply enclosure.



RISK OF FIRE:

- Follow all NEC and local codes.
- Use only UL approved wire for input/output connections. Minimum size 18 AWG (0.82 mm²)

This device complies with Part 15 of the FCC Rules. Operation is subject to the following two conditions: (1) this device may not cause harmful interference, and (2) this device must accept any interference received, including interference that may cause undesired operation. This Class [A] RFLD complies with the Canadian standard ICES-005. Ce DEFR de la classe [A] est conforme à la NMB-005 du Canada.

Conforms to the following standards:



6180 Halle Drive • Valley View, Ohio 44125-4635 • USA
P: 216.606.6555 • F: 216.606.6599 • www.led.com • info@led.com

For customer service & technical support, contact:
1-888-MY-GE-LED (1.888.694.3533)

Lumination, LLC is a subsidiary of the General Electric Company. Tetra is a trademark of Lumination, LLC. The GE brand, logo, and ecomagination are trademarks of the General Electric Company. © 2008 Lumination, LLC. Information provided is subject to change without notice. All values are design or typical values when measured under laboratory conditions.